

CERTIFICATION



HACCP International



ISO9001

# ICE MATE



## SRM-125UB ICE MAKER

ICEMATE is committed to bringing high-efficiency / energy-saving, and high quality ice-making product to people who have dreams and desire to create their own business with the best scientific technology and manufacturing technology.

**DICE**

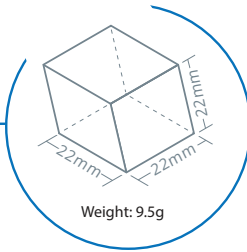

### KEY FEATURES

#### SAFETY AND HYGIENE ASSURED ICE MACHINE



NSF Certified Material for Bin and Scoop



Detachable Parts for Easy Cleaning



Air Filter Prevent Dust from Entering



Stainless Steel

#### PERFECT FIT & SPACE SAVING



Compact Design for Under-Counter Installations

EASY MAINTENANCE



IoT



AUTO-CLEANING



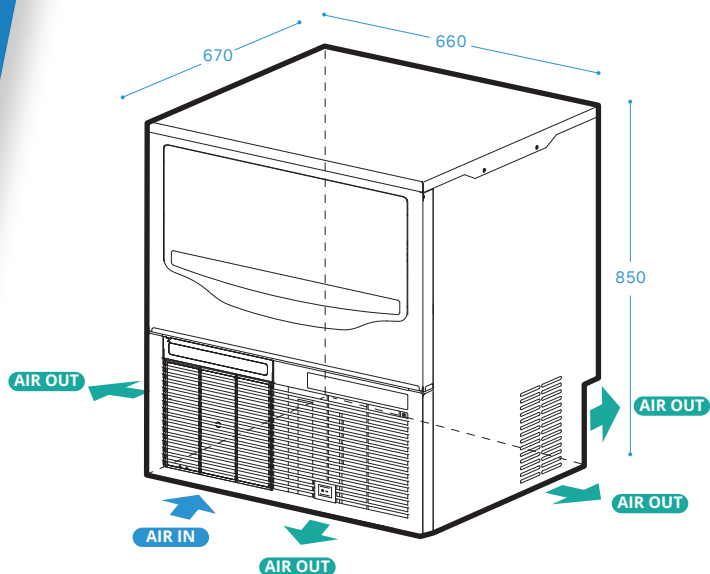

TOP SIDE

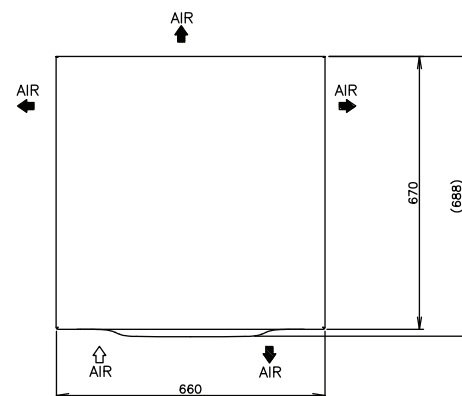

RIGHT SIDE

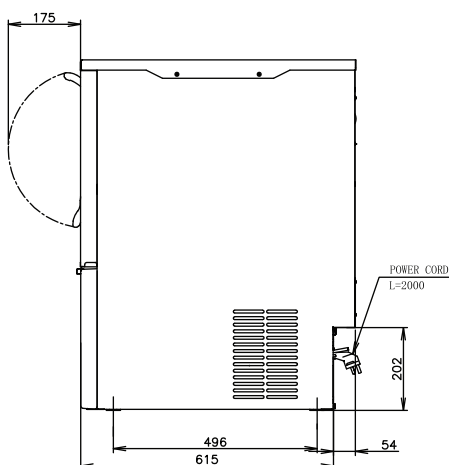

BACK SIDE

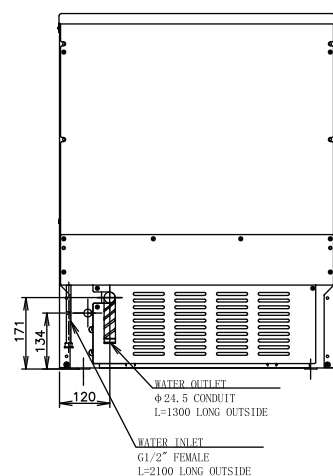

FRONT SIDE

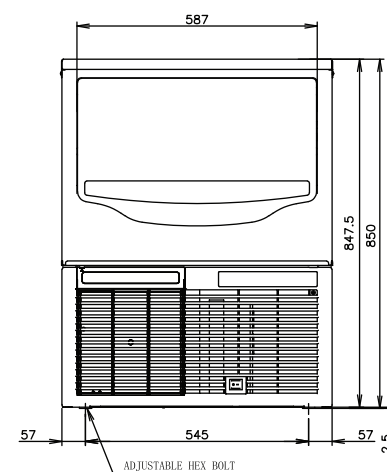

SPECIFICATIONS

Ice Dimensions (W x D x H)	22 x 22 x 22 mm
Outside Dimensions (W x D x H)	660 x 670 x 850 mm
Package Dimensions (W x D x H)	Carton: 780 x 850 x 1050 mm
Weight (Net / Gross)	58 kg / 75 kg
Amperage / Starting Amperage	5.05A / 20.4A
Electrical Consumption	(AT32°C / WT21°C) 590 W
Refrigerant Charge	R404A
Ice Storage Capacity	Maximum 24kg
Ice Production per 24H	(AT10°C / WT10°C) Approx. 125 kg (AT21°C / WT15°C) Approx. 106 kg (AT32°C / WT21°C) Approx. 81 kg

Water Consumption per 24H	(AT32°C/WT21°C) 0.17m <sup>3</sup> (2.1L / kg Ice)
Ice Production Freeze Cycle Time	(AT21°C/WT15°C) 15 min
Ice Production per Cycle	(AT21°C/WT15°C) Approx. 1.17kg / 126 pcs

OPERATING CONDITIONS

Voltage Range	198 - 254 V
Ambient Temperature	5 - 38°C
Water Supply	5 - 32°C
Water Supply Pressure	0.07 - 0.55 Mpa (0.7 - 5.5 bar)
Supply Voltage	1/220 - 240V / 50Hz



HOSHIZAKI

HOSHIZAKI VIETNAM CORPORATION

168/14 Nguyen Gia Tri, Thanh My Tay Ward, Ho Chi Minh City Vietnam 760000  
TEL +84 0 916 161 346 | <https://hoshizaki-sea.com/>